

HN10-WD MAG-TR

Screw plug w/ magnet

„System Bochumer Trichter“
with elastic seal

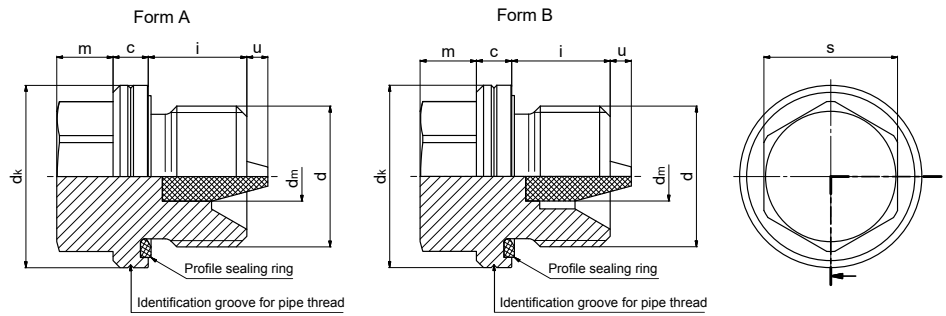

Function:

- Ferromagnetic wear debris is extracted from inside the aggregate with the help of the magnet.

Application areas:

- Engines, gearboxes, hydraulic equipment, powertrain and many others
- for counter bores as per DIN 3852-2 and EN ISO 9974-1
- can be undone and screwed in repeatedly

Industries:

- Mechanical engineering, gear manufacturing, steel construction, chemicals, automotive, and many others

Material (screw plug):

- Steel 11SMnPb30+C (1.0718)
DIN EN 10227-3 ultrasonic and crack tested or "HD-quality"
- Stainless steel 1.4305 / 1.4571
- other materials upon request

Coating (screw plug):

- Cr-(VI) free: nano passivated A3K/Zn Nano (ISO 4042)
- ZNNI as per VDA 235.104-25
- other coatings upon request

Profile sealing ring acc. DIN 3869:

- NBR 85 Shore -30°C to +100°C (-22°F to +212°F)
- FKM 80 Shore -20°C to +200°C (-4°F to +392°F)
- other temperature ranges upon request

Material (magnet):

- AlNiCo
- other magnets upon request

d		c	dk	i	m	s	u	d _m	Form	Weight
Metric fine thread	Pipe thread									
DIN 13	DIN EN ISO 228	+0,5	h14	±0,2	±0,35	h14	max.	±0,2	„Bochumer-Trichter“	~kg per 100 pieces
M8 x 1	—	4	12	8	6	8	3,0*	4	A	0,90
M10 x 1	—	4	14	8	6	10	3,0*	4	A	1,25
—	G 1/8 A	4	13,9	8	6	10	3,0*	5	A	1,30
M12 x 1,5	—	5	17	12	6	13	3,0*	5	A	2,30
—	G 1/4 A	5	18,9	12	6	13	3,5*	5	A	2,85
M14 x 1,5	—	5	19	12	6	13	3,5*	5	A	2,75
M16 x 1,5	—	5	21,9	12	6	17	3,5*	6	B	4,45
M18 x 1,5	—	5	23,9	12	8	17	3,5*	6	B	5,50
M20 x 1,5	—	5	25,9	14	8	19	3,5*	7	B	7,10
—	G 1/2 A	5	26,9	14	8	19	3,5*	7	B	7,55
M22 x 1,5	—	5	27	14	8	19	3,5*	7	B	7,85
M24 x 1,5	—	5	29,9	14	9	22	3,5*	7	B	10,20
M26 x 1,5	—	5	31,9	16	10	24	3,5*	7	B	13,20
—	M27 x 2	5	31,9	16	10	24	3,5*	7	B	13,65
M30 x 1,5	M30 x 2	6,5	36,9	16	10	24	3,5*	10	B	17,50
M33 x 1,5	M33 x 2	6,5	39,9	16	11	27	3,5*	10	B	20,60
M42 x 1,5	M42 x 2	6,5	49,9	16	12	30	3,5*	10	B	33,55
M48 x 1,5	M48 x 2	6,5	55	16	12	30	3,5*	12	B	40,50
—	G 2 A	6,5	68	20	15	36	3,5*	12	B	72,85

*Other magnet excess lengths upon request.

HN10-WD MAG-TR

Screw plug w/ magnet

„System Bochumer Trichter“
with elastic seal



Functional diagram of “Bochumer Trichter”

The conical form produces a larger adhesive surface.

The deep magnet enables the wear debris to be bound inside the hopper and not on the face of the magnet.

Due to the system-inherent short pole reversal towards the edge of the hopper, here is a larger adhesive surface.

The magnetic screw plugs remain very stable in the face of automatic self-demagnetisation.

Magnetic screw plugs with “Bochumer Trichter” and conical magnet generate almost 100% higher inductance values as against conventional magnetic screws. The results are a better filter output, greater adhesive force for the collected wear debris and improved magnetic stability. Therefore, these magnetic screw plugs are especially suitable where an optimal filter output is needed.

Flushing out of the deposited wear debris is prevented by the magnetic restricted zone and the high adhesive force. The level of the magnetic field can be determined by changing the magnet size.

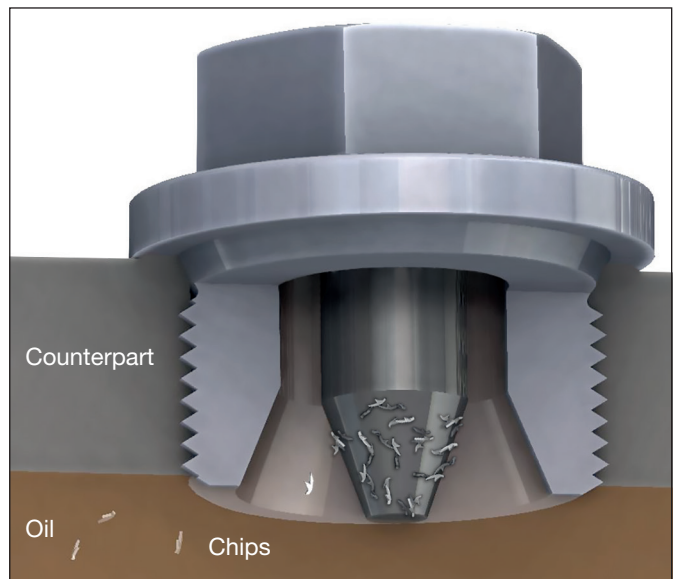

Picture 1: Chips are extracted from the oil

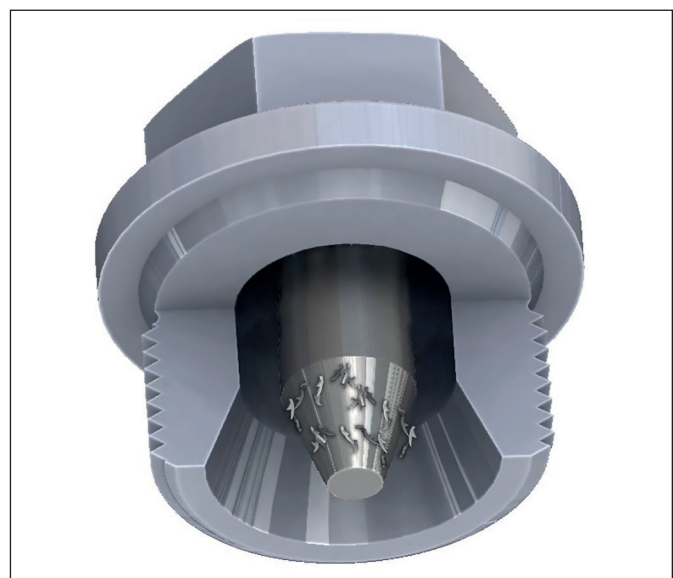

Picture 2: Chips are collected in the hopper